

CD PC FC SERIES

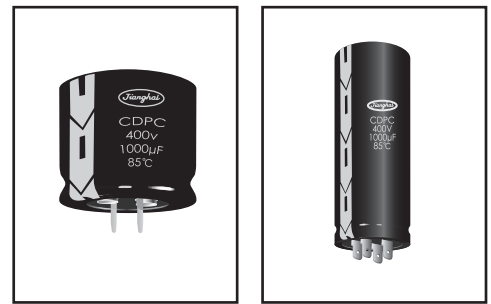

2000h at 85°C

- Withstands high-ripple current generated by the voltage doubler rectifier system of an inverter air conditioner.
- Adopting special electrode foil and electrolyte exclusive to this series has made high reliability a reality.
- Capacitors for voltage doubler rectifiers are available in pairs in a series.



Items	Characteristics
Operating Temperature Range (°C)	-25 ~ 85
Rated Voltage Range (V)	250, 400V
Capacitance Range (µF)	45 ~ 440
Capacitance Tolerance (20°C, 120Hz)	± 10%
Leakage Current (µA)	After 5 minutes at 20°C application of rated voltage, leakage current is not more than 0.01 CV or 5mA, whichever is smaller. C: Nominal Capacitance (µF) V: Rated Voltage (V)
Dissipation Factor (20°C, 120Hz)	Less than 0.05

Lifetime	Useful Life		Load Life	Endurance Test	Shelf Life
	4000h	≥ 65000h	2000h	2000h	500h
Leakage Current	Not more than specified value		Not more than specified value	Not more than specified value	Not more than specified value
Capacitance Change	Within ± 30% of initial value		Within ± 20% of initial value	Within ± 20% of initial value	Within ± 20% of initial value
Dissipation Factor	Not more than 300% of specified value		Not more than 200% of specified value	Not more than 200% of specified value	Not more than 200% of specified value
Condition: Applied Voltage Applied Current Applied Temperature	U_r I_r 85°C	U_r $1.2 \times I_r$ 40°C	U_r I_r 85°C	U_r $I_r = 0$ 85°C	$U_r = 0$ $I_r = 0$ 85°C After test: U_r to be applied for 30min >24h before measurement

Dimensions

mm

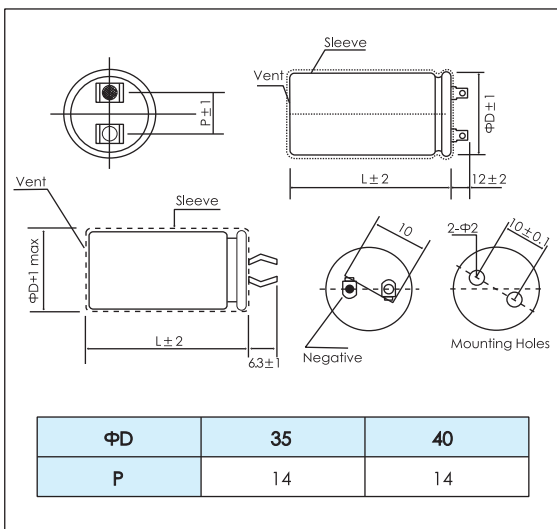

Frequency Coefficient

Frequency	50/60Hz	120Hz	400Hz	1kHz	≥ 10kHz
Coefficient	0.80	1.00	1.32	1.46	1.61

Lifetime Diagram

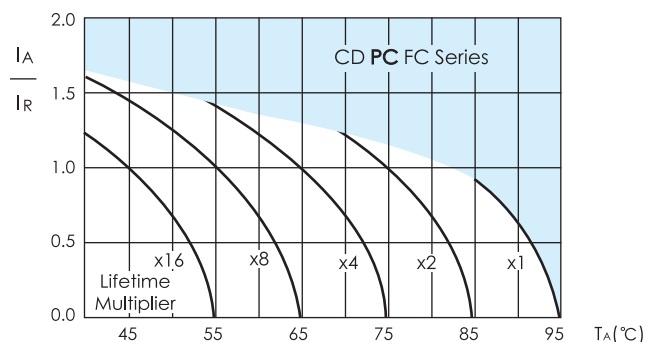

I_A = actual ripple current at 120Hz, I_R = rated ripple current at 120Hz, 85°C
Multiplier of Useful Life as a function of ambient temperature and ripple current load

Temperature Coefficient

Temperature(°C)	+40	+60	+70	+85
Coefficient	1.73	1.50	1.30	1.0



Ratings for CD PC FC Series

Snap-In (PCB Type)

U_R (Surge Voltage) Code	Rated Capacitance	Dissipation Factor	Max ESR 20°C, 120Hz	Rated Ripple Current 85°C, 120Hz	Size $\Phi D \times L$	P/N
(V)	(μF)	-	(Ω)	(Arms)	(mm)	-
250 (300) 2E	100	0.05	0.66	1.90	35 × 40	ECS2EFC101K350040
	110	0.05	0.60	2.00	35 × 40	ECS2EFC111K350040
	165	0.05	0.40	2.45	35 × 45	ECS2EFC16AK350045
	180	0.05	0.37	2.58	35 × 50	ECS2EFC181K350050
	195	0.05	0.34	2.68	35 × 50	ECS2EFC19AK350050
	210	0.05	0.32	2.78	35 × 50	ECS2EFC211K350050
	220	0.05	0.30	2.80	35 × 50	ECS2EFC221K350050
400 (450) 2G	45	0.05	1.47	1.50	35 × 50	ECS2GFC450K350050
	55	0.05	1.21	1.70	35 × 40	ECS2GFC550K350040
	75	0.05	0.88	1.98	35 × 50	ECS2GFC750K350040
	82	0.05	0.81	2.00	35 × 50	ECS2GFC820K350050

Lug (U Type)

U_R (Surge Voltage) Code	Rated Capacitance	Dissipation Factor	Max ESR 20°C, 120Hz	Rated Ripple Current 85°C, 120Hz	Size $\Phi D \times L$	P/N
(V)	(μF)	-	(Ω)	(Arms)	(mm)	-
250 (300) 2E	200	0.05	0.33	3.80	40 × 100	ECL2EFC201K400100
	220	0.05	0.30	4.00	40 × 100	ECL2EFC221K400100
	330	0.05	0.20	4.85	40 × 100	ECL2EFC331K400100
	360	0.05	0.18	5.10	40 × 100	ECL2EFC361K400100
	390	0.05	0.17	5.30	40 × 100	ECL2EFC391K400100
	420	0.05	0.16	5.50	40 × 100	ECL2EFC421K400100
	440	0.05	0.15	5.60	40 × 100	ECL2EFC441K400100
	400 (450) 2G	90	0.05	0.74	3.00	35 × 80
0.05			0.74	3.00	40 × 80	ECL2GFC900K400080
100		0.05	0.66	3.20	35 × 90	ECL2GFC101K350090
		0.05	0.66	3.20	40 × 90	ECL2GFC101K400090
110		0.05	0.60	3.30	35 × 100	ECL2GFC111K350100
		0.05	0.60	3.30	40 × 100	ECL2GFC111K400100
150		0.05	0.44	3.90	35 × 100	ECL2GFC151K350100
		0.05	0.44	3.90	40 × 100	ECL2GFC151K400100
165		0.05	0.40	4.10	40 × 100	ECL2GFC16AK400100
220		0.05	0.30	4.70	40 × 100	ECL2GFC221K400100

Customer products are available on request.

Typical Curves

